

Message handbook for Ediel

Implementation guide for APPLICATION ERROR AND ACKNOWLEDGEMENT MESSAGE

SUOMESSA KÄYTETTÄVÄ VERSIO

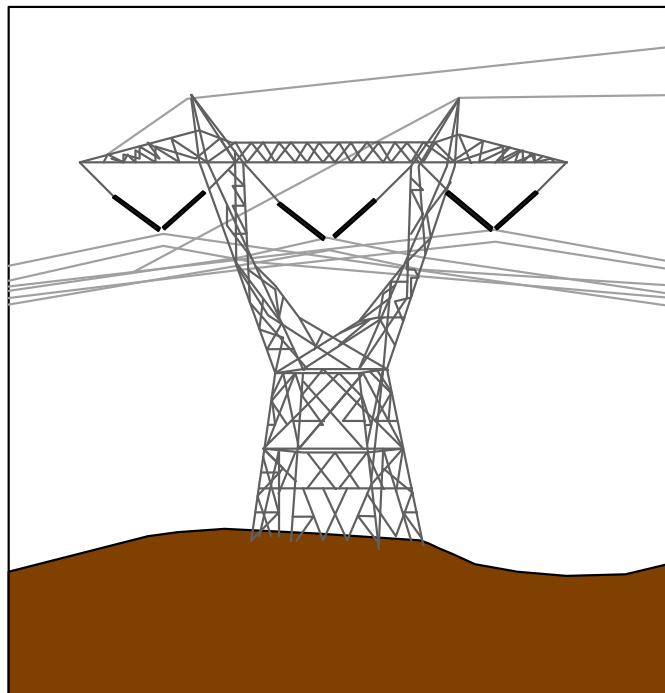

EDIFACT-message:	Extended APERAK
EDIFACT-version:	D
EDIFACT-release:	96A
IG-status:	Planned as 2.4A
IG-version:	2.4 AFI
IG-revision:	E2FI01
IG-date:	September, 9 th , 2009
Laatija:	Energiateollisuus ry / Tekninen ryhmä

C O N T E N T

1. INTRODUCTION.....	3
2. GENERAL DESCRIPTION OF THE APERAK MESSAGE.....	4
2.1. FUNCTIONAL DEFINITION.....	4
2.2. PRINCIPLES	4
3. REFERENCES.....	5
3.1. PRECEDENCE.....	5
4. QUALITY ASSURANCE	6
4.1. VERSION NUMBER	6
4.2. CORRECTIONS FROM EARLIER VERSIONS	6
5. OVERVIEW OF THE MESSAGE	9
5.1. DATA MODEL FOR THE APPLICATION ERROR AND ACKNOWLEDGEMENT MESSAGE	9
5.2. CUE LIST	10
5.3. MESSAGE DIAGRAM	11
5.4. SEGMENT TABLE	12
5.5. DESCRIPTION OF SEGMENTS USED	13
6. DETAILED DESCRIPTION OF THE MESSAGE.....	15
APPENDIX A EXAMPLES OF EDIFACT MESSAGES.....	28

1. INTRODUCTION

This document is an Implementation Guide (IG) for the application error and acknowledgement message, to be used in the power industry. The IG describes the EDIFACT-message APERAK (Application error and acknowledgement message) in detail. The message is sent between parties in the power industry and is used to acknowledge messages.

Note: The number of repetitions of segment group 4 is increased from 1 to 4 in comparison to the EDIFACT UNSM message. The number of repetition is increased from 1 to 9 from EDIFACT directory D.97B.

This IG is a part of the "Message handbook for Ediel", which contains a set of IG's for different messages used in the power industry and a functional description, which contains common descriptions for the different IG's. In the future several new IG's are planned.

In addition a Functional description is available, which contains common descriptions for the different Implementation Guides. This includes relationships between the different message types, use of codes and code lists, special conditions between countries (such as use of time zones), terms and notation, use of header and trailer segments (UNB and UNZ), etc.

2. GENERAL DESCRIPTION OF THE APERAK MESSAGE

2.1. Functional Definition

The function of this message is:

- a) to inform a message issuer that his message has been received by the addressee's application and has been rejected due to errors encountered during its processing in the application.
- b) to acknowledge to a message issuer the receipt of his message by the addressee's application.

2.2. Principles

A message, (i. e. DELFOR, MSCONS, etc.) being first controlled at system level (CONTRL) to detect syntax errors and to acknowledge its receipt is then transmitted to the application process to be processed.

If an error is detected at the application level, which prevents its complete processing, an APERAK message is sent to the original message issuer giving details of the error(s) encountered. If no error has been detected and when an acknowledgement is necessary (e. g. when no dedicated answer to the original message exists) an APERAK message is sent specifying the reasons for acknowledgement.

In case of an application error, the APERAK message will need manual processing e. g. when the underlying reason is a programming error. In case of acknowledgement the APERAK message may be automatically or manually processed at the recipient's discretion.

The information is transferred as:

- General information
- Reference to received message
- In case of error: Error information

Note: If an APERAK message is requested a CONTRL message is not normally necessary.

3. REFERENCES

This Implementation guide is based on the following documents.

- [1] **Norsk veiledning i bruk av EDIFACT**, version 2.0, November 1991 with addition of January 1994.
- [2] **UN/EDIFACT Draft directory**, D.96A
- [3] **Message handbook for Ediel, Functional description**
- [4] **ISO 9735**, version 2, 1990.11.01

3.1. Precedence

If there should be any conflict regarding this Implementation guide or between this Implementation guide and other documents, the following precedence shall be used:

- 1 UN/EDIFACT Draft directory, D.96A [2]
- 2 The Functional description [3]
- 3 This Implementation guide.

In this Implementation guide the EDIFACT message type is described in different ways. If there should be any conflict regarding the different descriptions, the detailed description in the last chapter should be used.

4. QUALITY ASSURANCE

This document is written by EdiSys AS on behalf of Ediel. Members of the Ediel-organisation have taken part in its development throughout.

The present document has the following status:

- **For implementation**

4.1. Version number

The Implementation Guide will have 2 levels of version numbering. This will be Version and Release. In addition there will be a Revision number.

- The Version number (first number) will be updated when there have been major changes like new versions of the message type.
- The Release number will be updated when there have been small changes to the IG, like adding new segments, new data elements etc. within the EDIFACT directory. These changes shall not influence existing implementations.
- The Revision number will be updated when there have been minor changes, like correction of examples, adding new codes etc. These changes shall not influence existing implementations.

4.2. Corrections from earlier versions

In addition to minor text corrections the following changes has been made to this version of the IG:

Corrections from version 2.4.AFI:

- Added Finnish national exceptions, marked with red color.
- From **SG0 / BGM** (p. 17), **SG3 / ERC** (p. 24) and **SG4 / RFF** (p. 26) deleted codes which are not used in Finland.

Corrections from version 2.4.A:

- Numbers of repetitions in Figure 2 are corrected.

Corrections from version 2.3.G:

- The code “EM, Electronic mail” is added as a communication channel to the COM segment.
- It is opened for the usage of UNH/0068 (COMMON ACCESS REFERENCE).
- The code “305, ETSO (European Transmission System Operator)” is added as code list responsible together with EAN, where relevant.
- The code “DK, Danish Ediel group” is added as code list responsible in all relevant segments where code list responsables are used.
- The usage of data element UNH/S009 0057 is changed. It is now possible to add a version number of the relevant national user guide.

- The code list for ERC/9321 is enhanced with new codes.

Corrections from version 2.3.F:

- A reference to “ISO 3166-1 two alpha country code“ is added to NAD.

Corrections from version 2.3.E:

- The data element 4441 is added to the FTX segment in SG3.

Corrections from version 2.3.D:

- The repetitions of data element 4440 in FTG/SG3 are increased from 1 to 5.
- The number of repetitions of segment group 4 is increased from 1 to 3 in comparison to the EDIFACT UNSM message. The number of repetition is increased from 1 to 9 from EDIFACT directory D.97B.
- The code AES in RFF/SG4 is changed to “ACW - Reference number to previous message” to be in compliance with the codes used in other Ediel IGs
- The classification of SG1 is changed from R to D
- The classification of SG4 is changed from O to D

Corrections from version 2.3.C:

- The codes “100 - The object is approved” and “101 - The object is not processed” are added to SG3/ERC.
- The codes “AOB - Originator’s reference” and “Z07 - Metering point identification” are added to SG4/RFF.

Corrections from version 2.3.B:

- The code “34 Accepted with amendment” is added to data element 1225 in the BGM segment.

Corrections from version 2.3.A:

- A number of error codes are added to the ERC segment in SG3.
- The code “ZZZ – Ediel Nordic Forum” is added to data element C901 3055 in the ERC segment in SG3.
- An advice to use English text and to state the field name and content that have caused an error are added to the FTX segment in SG3.

Corrections from version 2.2.1:

- DE, NL and GB are added as country codes in the NAD segment.
- Some general paragraphs from chapter 1 are removed. This information will be found in the Functional description.
- The text in chapter 4.1, Version number, is changed to be more compliant with practice.

Corrections from version 2.2.0:

- The code “EKS” for Elkraft (as code list responsible agency) is added in segment ERC in SG 3.

Corrections from version 2.1.0:

- The code “ELT” for Eltra (as code list responsible agency) is added in segment ERC in SG 3.

Corrections from version 2.0.0:

- Only minor text corrections.

Main corrections from version 1.x.x:

- The Message version is updated to version D.96A.
- The NAD segment in segment group 2 is extended with 1 party qualifier. The segment can be repeated 4 times.
- The Association assigned code in UNH is changed from EDIEL to EDIEL2.

5. OVERVIEW OF THE MESSAGE

5.1. Data model for the Application error and acknowledgement message

Shown below a data model for the Application error and acknowledgement message:

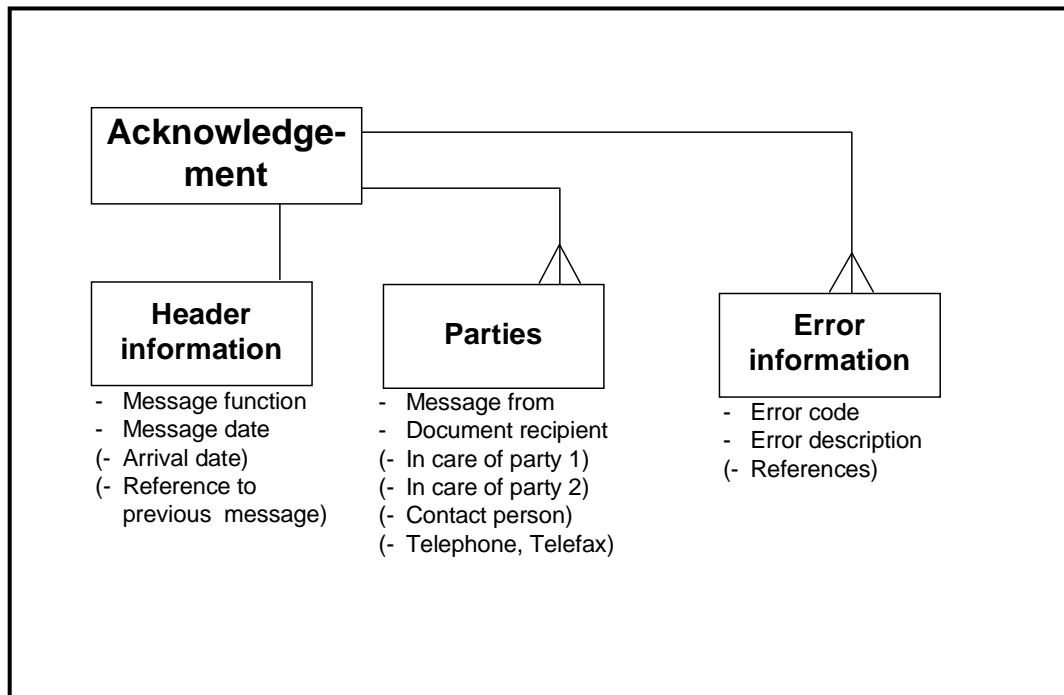

Figure 2 Data model for application error and acknowledgement

The Attributes in parentheses are conditional attributes and are not necessarily transferred.

5.2. Cue list

Below is a table describing the EDIFACT message and the relationships to the attributes in the data model.

Note: The number of repetitions of segment group 4 is increased from 1 to 4 in comparison to the EDIFACT UNSM message. The number of repetition is increased from 1 to 9 from EDIFACT directory D.97B.

General information about the message				
UNH	M	1	Message reference Message type	
BGM	M	1	Message function	
DTM	R	2	Message date (Arrival date)	
References				
SG 1	D	1		
RFF	M	1	Reference to previous message	
Parties				
SG 2	R	4		
NAD	M	1	Message from Document recipient (In care of party 1) (In care of party 2)	
CTA	O	1	(Contact person)	
COM	O	3	(Telephone, Telefax, e-mail)	
Error status				
SG 3	D	999		
ERC	M	1	Error code	
FTX	A	1	Error description	
Reference to Serial Id.				
SG 4	D	4		
RFF	M	1	(References)	
Message trailer				
UNT	M	1	Message trailer	

As a minimum the segment groups (with corresponding segments) marked with R or M have to be used in every message.

5.3. Message diagram

The Message diagram below shows the subset of the standard EDIFACT message that is used in this IG. All segments and segment groups are shown according to the classification in this subset. For a complete overview of the EDIFACT standard message, please see the next chapter (segment table).

Note: The number of repetitions of segment group 4 is increased from 1 to 4 in comparison to the EDIFACT UNSM message. The number of repetition is increased from 1 to 9 from EDIFACT directory D.97B.

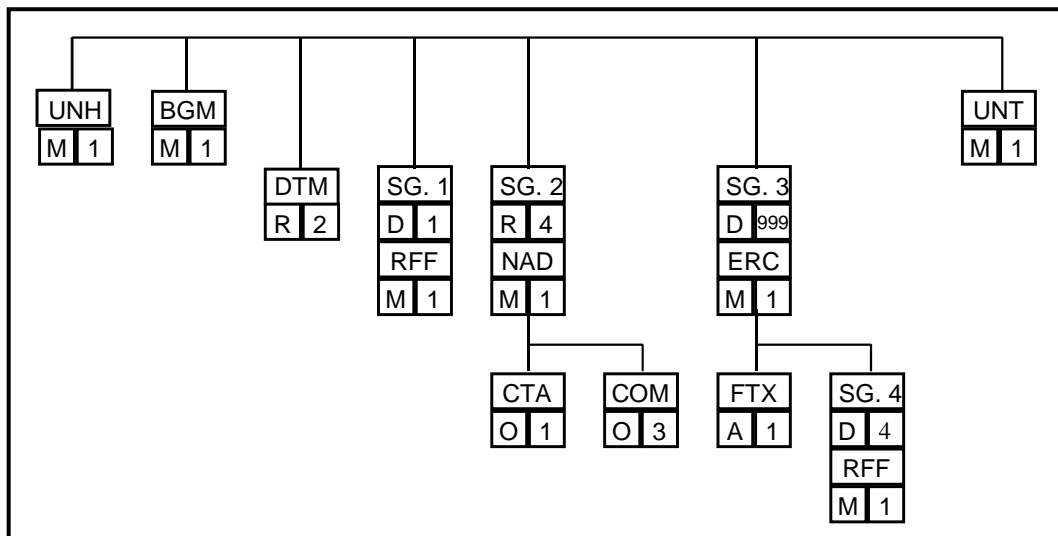

Figure 2 Message diagram for Application error and acknowledgement message

5.4. Segment table

In this chapter the segment table for the Application error and acknowledgement message (APERAK) is shown by the way it is described in version D, release 96A of the EDIFACT directory. The segments and segment groups that are used in this IG are shown in bold type.

Note: The number of repetitions of segment group 4 is increased from 1 to 4 in comparison to the EDIFACT UNSM message. The number of repetition is increased from 1 to 9 from EDIFACT directory D.97B.

HEADER SECTION

UNH Message header	M	1	
BGM Beginning of message	M	1	
DTM Date/time/period	C	9	
FTX Free text	C	9	
CNT Control total	C	9	
----- Segment group 1 -----			
RFF Reference	M	1	-----+
DTM Date/time/period	C	9	-----+
----- Segment group 2 -----			
NAD Name and address	M	1	-----+
CTA Contact information	C	9	-----+
COM Communication contact	C	9	-----+
----- Segment group 3 -----			
ERC Application error information	M	1	-----+
FTX Free text	C	1	-----+
----- Segment group 4 -----			
RFF Reference	M	1	-----+
FTX Free text	C	9	-----+
UNT Message trailer	M	1	-----+

5.5. Description of segments used

The segments and segment groups used in this IG are described below. The description is copied from version D, release 96A of the UN/EDIFACT directory. *The way Ediel uses the segments are described in the next chapter.*

UNH, Message header

A service segment starting and uniquely identifying the message. The message type code for the Application error and acknowledgement message is APERAK.

Note: Application error and acknowledgement messages conforming to this document must contain the following data in segment UNH, composite S009:

Data element 0065 APERAK
0052 D
0054 96A
0051 UN

BGM, Beginning of message

A segment to indicate the type and function of the message and to transmit the identifying number.

DTM, Date/time/period

A segment to specify related date/time.

Segment Group 1: RFF

A group of segments to specify the document/message to which the current message relates, and related date and time.

RFF, Reference

A segment to indicate the reference number of the document/message.

Segment Group 2: NAD-CTA-COM

A group of segments to specify the identifications of message sender and message receiver with their contacts and communication channels.

NAD, Name and address

A segment to specify the identification of the message issuer and message receiver.

CTA, Contact information

A segment to specify a person or department inside the party's organisation, to which communication should be directed.

COM, Communication contact

A segment to indicate communication channel type and number inside the party's organisation, to which communication should be directed.

Segment Group 3: ERC-FTX

A group of segments to identify the application error(s) within a specified received message and to give specific details related to the error type or to precise the type of acknowledgement.

ERC, Application error information

A segment identifying the type of application error or acknowledgement within the referenced message. In case of an error, the error code may specify the error in detail (e. g. a measurement relating to a piece of equipment is wrong) or as a rough indication (e. g. a measurement is wrong).

FTX, Free text

A segment to provide explanation and/or supplementary information related to the specified application error or acknowledgement. For example, the explanation may provide exact details relating to a generic error code.

Segment group 4: RFF

A group of segments to specify the functional entity reference (e. g. goods item level, equipment level) relating to the specified error; further details can be added to identify the error more precisely.

RFF, Reference

A segment to provide a reference relating to the acknowledgement type or the specified error (e. g. functional entity reference such as equipment level).

UNT, Message trailer

A service segment ending a message, giving the total number of segments in the message and the control reference number of the message.

6. DETAILED DESCRIPTION OF THE MESSAGE

In this chapter all segments and segment groups are specified in detail. In the left column you will find a list of the attributes used.

The EDIFACT segments listed are copies of those defined in the original UN/EDIFACT directory except for data elements defined as conditional (C) which are redefined using the classification described in the Functional Description [3].

Note: The number of repetitions of segment group 4 is increased from 1 to 4 in comparison to the EDIFACT UNSM message. The number of repetition is increased from 1 to 9 from EDIFACT directory D.97B.



MESSAGE: APERAK

SG 0

Function: Application error and acknowledgement message is sent between parties in the power industry, and is used to acknowledge messages.

Segments: UNH, BGM, DTM

UNH Message header

Function: A service segment to start and identify a message.

Classification: Mandatory (M1).

Comments:

Example: UNH+1+APERAK:D:96A:UN:EDIEL2'

Example FI: UNH+1+APERAK:D:96A:UN:E2FI01'

Message-reference

>

Ref.	Name	Cl.	Form.	Description
0062	MESSAGE REFERENCE NUMBER	M	an..14	The message reference uniquely identifies the message in the interchange. This can for instance be done by using a sequence number that identifies each message in the interchange. The first message will have reference no. 1, the second message will have reference 2, etc. The reference can be set to 1 in the first message of the next interchange.
S009	MESSAGE IDENTIFIER	M		
0065	Message type identifier	M	an..6	Code: APERAK
0052	Message type version number	M	an..3	Code: D
0054	Message type release number	M	an..3	Code: 96A
0051	Controlling agency	M	an..2	Code: UN
0057	Association assigned code	R	an..6	Use the code "EDIEL2" if the Ediel IG is implemented in its full version, Finnish version code "E2FI01" or a code of the format "E2yyzz" if a national IG is the basis, where: E2 Indicates Ediel version 2 yy ISO 2 letter country code or an abbreviation for an international organisation (FI for Finland) zz user guide or national implementation guide version number (01 for Finland)
0068	COMMON ACCESS REFERENCE	X	an..35	May be used to identify a "business transaction" according to national specifications.
S010	STATUS OF THE TRANSFER	X		

Message-type

>

0070	Sequence message transfer number	X	n..2	
0073	First/last seq. mess. transfer. indicator.	X	a1	

BGM Beginning of message
Function: A segment to indicate the function of the message.
Classification: Mandatory (M1).
Comments:

- The code “12” in data element 1225 is to be used if the received message is being verified manually. This should later result in a new APERAK with code “27”, “29”, “34” or a manual acknowledgement.
- The code “34” in data element 1225 is to be used if the received message is partly accepted. **For PRODAT replies the code “34” tells if APERAK message includes both accepted and not-accepted events.**

Example: BGM+++27'

Message function

Ref.	Name	Cl.	Form.	Description
C002	DOCUMENT/MESSAGE NAME	X		
1001	Document/message name, coded	D	an..3	Not used for Prodat
1131	Code list qualifier	X	an..3	
3055	Code list responsible agency, coded	X	an..3	
1000	Document/message name	X	an..35	
1004	DOCUMENT/MESSAGE NUMBER	X	an..35	
1225	MESSAGE FUNCTION, CODED	R	an..3	Code: 27 Not accepted 29 Accepted without amendment 34 Partly accepted
4343	RESPONSE TYPE, CODED	X	an..3	

Message date	>	DTM	Date/time/period		
		Function:	A segment specifying the message date.		
		Classification:	Required (R2).		
		Comments:	Arrival date is optional.		
		Example:	DTM+137:199905011241:203'		
Ref.	Name	Cl.	Form.	Description	
C507	DATE/TIME/PERIOD	M			
2005	Date/time/period qualifier	M	an..3	Code: 137 Message date 178 Arrival date/time, actual	
2380	Date/time/period	R	an..35	Date/time/period	
2379	Date/time/period format qualifier	R	an..3	Code: 203 CCYYMMDDHHmm	



MESSAGE: APERAK

SG 1

Function: A group of segments giving references relevant to the whole message, e. g. Reference to earlier received message.
Classification: Dependent (D1).
Comments: A reference to the object being acknowledged must be sent in this segment group or in RFF/SG4.
Segments: RFF

RFF Reference
Function: A segment to indicate the reference number of the original document/message received.
Classification: Mandatory (M1).
Comments: The message Id., in data element 1004, in the BGM segment of the relevant received (original) message **id** is to be used.
Example: RFF+ACW:ABC001582'

Reference

>

Ref.	Name	Cl.	Form.	Description
C506	REFERENCE	M		
1153	Reference qualifier	M	an..3	Code: ACW Reference number to previous message
1154	Reference number	R	an..35	Reference no.
1156	Line number	X	an..6	
4000	Reference version number	X	an..35	



MESSAGE: APERAK

SG 2

Function: A group of segments to specify the identifications of message sender, message receiver, in care of parties, contacts and communication channels.
Classification: Required (R4).
Comments: Two repetitions are required.
Segments: NAD, CTA, COM

NAD Name and address
Function: A segment to specify the identification of the message issuer, message receiver and operator.
Classification: Mandatory (M1).
Comments:

- See the Functional description for a description of the use of data elements C082 1131 and C082 3055.
- Code «FR» and «DO» in data element 3035 are required

Example: NAD+FR+123456789:NO3:82++++OSLO+++NO'
Example FI: NAD+FR+TST000:160:SLY'

Party Id.

>

Code list responsible

>

Ref.	Name	Cl.	Form.	Description
3035	PARTY QUALIFIER	M	an..3	Code: FR Message from DO Document recipient C1 In care of party no. 1 C2 In care of party no. 2
C082	PARTY IDENTIFICATION DETAILS	R		
3039	Party id identification	M	an..35	Party identification
1131	Code list qualifier	D	an..3	Code: 100 Enhanced party identification 160 Party identification NO3 Company registration no. from «Foretaksregisteret» in Norway
3055	Code list responsible agency, coded	R	an..3	Code: 9 EAN (International Article Numbering association) 82 «Enhetsregisteret» in Norway 305 ETSO (European Transmission System Operator) EDI Other Id. than power plant SLY Finnish Electricity Association SM Nord Pool ASA SVK Svenska Kraftnät
C058	NAME AND ADDRESS	X		
3124	Name and address line	X	an..35	
3124	Name and address line	X	an..35	
3124	Name and address line	X	an..35	
3124	Name and address line	X	an..35	
3124	Name and address line	X	an..35	

Place	>	C080	PARTY NAME	X		
		3036	Party name	X	an..35	
		3036	Party name	X	an..35	
		3036	Party name	X	an..35	
		3036	Party name	X	an..35	
		3036	Party name	X	an..35	
		3045	Party name format, coded	X	an..3	
Country	>	C059	STREET	X		
		3042	Street and number/P.O. Box	X	an..35	
		3042	Street and number/P.O. Box	X	an..35	
		3042	Street and number/P.O. Box	X	an..35	
		3164	CITY NAME	O	an..35	Place (for generation of message)
		3229	COUNTRY SUB-ENTITY IDENTIFICATION	X	an..9	
		3251	POSTCODE IDENTIFICATION	X	an..9	
		3207	COUNTRY, CODED	O	an..3	Code: Use ISO 3166-1 two alpha country code, e.g.: DK Denmark FI Finland DE Germany NL Netherlands NO Norway SE Sweden GB United Kingdom

Contact

Communication number

CTA Contact information
Function: A segment to identify the person, or department to whom communication should be directed.
Classification: Optional (O1).
Comments:

- Advised to be used when an error has occurred. I. e. when Message function code in BGM is 27.
- Normally used for sender (code «FR» in NAD, SG. 2)
 - «MR» is used together with «DO» in NAD, SG. 2
 - «MS» is used together with «FR» in NAD, SG. 2
 - «IC» is used together with «C1» in NAD, SG. 2

Example: CTA+MS+:Ole Olsen'

Ref.	Name	Cl.	Form.	Description
3139	CONTACT FUNCTION, CODED	R	an..3	Code: IC Information contact MR Message recipient contact MS Message sender contact
C056	DEPARTMENT OR EMPLOYEE DETAILS	R		
3413	Department or employee identification	X	an..17	
3412	Department or employee	R	an..35	Contact person or department

COM Communication contact
Function: A segment to indicate communication channel type and number inside the party's organisation, to which communication should be directed.
Classification: Optional (O3).
Comments: Advised to be used when an error has occurred. I. e. when Message function code in BGM is 27.
Example: COM+4687397775:TE'

Ref.	Name	Cl.	Form.	Description
C076	COMMUNICATION CONTACT	M		
3148	Communication number	M	an..512	Communication number
3155	Communication channel qualifier	M	an..3	Code: FX Fax TE Telephone EM Electronic mail



MESSAGE: APERAK

SG 3

Function: A group of segments to identify the application error(s) within a specified received message and to give specific details related to the error type or to precise the type of acknowledgement.

Classification: Dependent (D999).

Comments: Shall be used when an error has occurred, i. e. when Message function code in BGM is 27 or 34.

Segments: ERC, FTX

ERC Application error information

Function: A segment identifying the type of application error or acknowledgement within the referenced message. It is advisable to explain the error code in the FTX segment in segment group 3.

Classification: Mandatory (M1).

Comments:

- Other error codes can be defined bilaterally.
- It is advised to state the field name and content that have caused an error in the FTX segment below, if possible.
- If error codes from the list below are used, the code list responsible should be “ZZZ - Ediel Nordic Forum”

Example: ERC+51::ZZZ'

Ref.	Name	Cl.	Form.	Description
C901	APPLICATION ERROR DETAIL	M		
9321	Application error, coded	M	an..3	Code: 41 Required data missing. 42 Error in content of a data element. 45 <u>The format of a data element is not allowed.</u> 46 <u>Maximum number of repetitions of a data element is exceeded.</u> 47 The identification is not unique 50 Error in the message period (e. g. the data in the message is too old) 51 The message was received too late (e. g. time critical DELFOR message) 60 The object of the transaction is not recognised (e. g. sent to the wrong receiver) 100 The object is approved 101 The object is not processed 999 General error (an error description should be stated in the FTX segment).
1131	Code list qualifier	X	an..3	
3055	Code list responsible agency, coded	R	an..3	Code: ZZZ Ediel Nordic Forum DK Danish Ediel group ELT Eltra EKS Elkraft SLY Finnish Electricity Association SM Nord Pool ASA SVK Svenska Kraftnät

FTX Free text

Function: A segment to provide explanation and/or supplementary information related to the specified application error or acknowledgement. E. g. the explanation may provide exact details relating to a generic error code. A segment with free text in clear form to give further clarification when required.

Classification: Advised (A1).

Comments:

- The segment is used if there is an error description connected to the error code in the ERC segment
- Composite C107 may be used for detailed error codes.
- If the information in the FTX-segment is given in free text format, it may be difficult to process by an application. The receiver must however handle the information.
- It is advised to state the field name and content that have caused an error, if possible.

Example: FTX+AAO+++Message received too late'

Error description

Ref.	Name	Cl.	Form.	Description
4451	TEXT SUBJECT QUALIFIER	M	an..3	Code: AAO Error description
4453	TEXT FUNCTION, CODED	X	an..3	
C107	TEXT REFERENCE	O		
4441	Free text, coded	M	an..3	Error description, coded
1131	Code list qualifier	O	an..3	
3055	Code list responsible agency, coded	O	an..3	Code: 260 Ediel Nordic forum DK Danish Ediel group ELT Eltra EKS Elkraft SLY Finnish Electricity Association SM Nord Pool ASA SVK Svenska Kraftnät
C108	TEXT LITERAL	R		
4440	Free text	M	an..70	Error description
4440	Free text	O	an..70	Error description
4440	Free text	O	an..70	Error description
4440	Free text	O	an..70	Error description
4440	Free text	O	an..70	Error description
3453	LANGUAGE	X	an..3	



MESSAGE: APERAK

SG 4

Function: A group of segments to specifying references connected to an error code.
Classification: Dependent (D4).
Comments: A reference to the object being acknowledged must be sent in this segment group or in RFF/SG1.
Segments: RFF

RFF Reference
Function: A segment for specifying references connected to an error code.
Classification: Mandatory (M1).
Comments:

- The number of repetitions of segment group 4 is increased from 1 to 4 in comparison to the EDIFACT UNSM message. The number of repetition is increased from 1 to 9 from EDIFACT directory D.97B.
- AES - Primary reference, is used to reference a Serial Id.
- Z07 - Metering point identification, should be used to reference the “metering point id.” (Object id.) from a previous message (PRODAT/UTILMD).

Example: RFF+AES:S-12345'

Example FI: RFF+Z07:FI_TST000_JVH0101'

Example FI: RFF+AIV:Z03_1_TST_TST000_3645282040'

Serial Id.

>

Ref.	Name	Cl.	Form.	Description
C506	REFERENCE	M		
1153	Reference qualifier	M	an..3	Code: AES Primary reference (timeseries code = aikasarjatunnuksen koodi) (DELFOR, MSCONS) Z07 Metering point identification (PRODAT) AIV Event reference (PRODAT) Serial Id. (Aikasarjatunnus, käyttöpaikkatunnus)
1154	Reference number	R	an..35	
1156	Line number	X	an..6	
4000	Reference version number	X	an..35	



MESSAGE: APERAK

SG 0

Function: Summary section
Classification: Mandatory (M1).
Comments:
Segments: UNT

UNT Message trailer
Function: A service segment ending a message, giving the total number of segments in the message and the control reference number of the message.
Classification: Mandatory (M1).
Comments:
Example: UNT+11+1'

Ref.	Name	Cl.	Form.	Description
0074	NUMBER OF SEGMENTS IN THE MESSAGE	M	n..6	Number of segments in the message, including UNH and UNT.
0062	MESSAGE REFERENCE NUMBER	M	an..14	Control reference number. Equal to 0062 in UNH

Appendix A FINNISH EXAMPLES OF EDIFACT MESSAGES

Original PRODAT

Corresponding APERAK

34: Partly accepted

UNA:+.? '
UNB+UNOC:3+TST:SLY+TST000:SLY+090908:1423+1111'
UNH+1+PRODAT:D:97A:UN:E2FI01'
BGM+Z03+0000000000115+9+AB'
DTM+137:200909081123:203'
DTM+ZZZ:0:805'
NAD+FR+TST:160:SLY'
NAD+DO+TST000:160:SLY'
NAD+C1+TST:160:SLY'
NAD+C2+TST000:160:SLY'
LIN+1+1+FI_TST000_JVH0101:::SLY'
DTM+92:200909302100:203'
CCI++ZZ1'
CAV+ZIV:::1'
RFF+AIV:Z03_1_TST_TST000_3645282040'
RFF+VC:contract1'
NAD+IT++++Haukitie 2 B 4+ESPOO++02150+FI'
LIN+2+1+FI_TST000_JVH0301:::SLY'
DTM+92:200909302100:203'
CCI++ZZ1'
CAV+ZIV:::1'
RFF+AIV:Z03_1_TST_TST000_2825971885'
RFF+VC:'
NAD+IT++++Vanhamäentie 420+MIKKELI++50600+FI'
UNT+23+1'
UNZ+1+1111'

UNA:+.? '
UNB+UNOB:2+TST000:SLY+TST:SLY+090908:1425+2222'
UNH+1+APERAK:D:96A:UN:E2FI01'
BGM+++34'
DTM+137:200909080825:203'
DTM+178:200909081123:203'
RFF+ACW:0000000000115'
NAD+FR+TST000:160:SLY'
NAD+DO+TST:160:SLY'
NAD+C1+TST000:160:SLY'
NAD+C2+TST:160:SLY'
ERC+100::SLY'
RFF+Z07:FI_TST000_JVH0101'
RFF+AIV:Z03_1_TST_TST000_3645282040'
ERC+41::SLY'
FTX+AAO+++ContractId missing'
RFF+Z07:FI_TST000_JVH0301'
RFF+AIV:Z03_1_TST_TST000_2825971885'
UNT+17+1'
UNZ+1+2222'

29: Accepted

UNA:+.? '
UNB+UNOC:3+TST:SLY+TST000:SLY+090908:1503+3333'
UNH+1+PRODAT:D:97A:UN:E2FI01'
BGM+Z03+0000000000116+9+AB'
DTM+137:200909081203:203'
DTM+ZZZ:0:805'
NAD+FR+TST:160:SLY'
NAD+DO+TST000:160:SLY'
NAD+C1+TST:160:SLY'
NAD+C2+TST000:160:SLY'
LIN+1+1+FI_TST000_JVH0101:::SLY'
DTM+92:200909302100:203'
CCI++ZZ1'
CAV+ZIV:::1'
RFF+AIV:Z03_1_TST_TST000_3645282041'
RFF+VC:contract1'
NAD+IT++++Haukitie 2 B 4+ESPOO++02150+FI'
LIN+2+1+FI_TST000_JVH0301:::SLY'
DTM+92:200909302100:203'
CCI++ZZ1'
CAV+ZIV:::1'
RFF+AIV:Z03_1_TST_TST000_2825971886'
RFF+VC:contract2'
NAD+IT++++Vanhamäentie 420+MIKKELI++50600+FI'
UNT+23+1'
UNZ+1+3333'

UNA:+.? '
UNB+UNOB:2+TST000:SLY+TST:SLY+090908:1504+4444'
UNH+1+APERAK:D:96A:UN:E2FI01'
BGM+++29'
DTM+137:200909080904:203'
DTM+178:200909081204:203'
RFF+ACW:0000000000116'
NAD+FR+TST000:160:SLY'
NAD+DO+TST:160:SLY'
NAD+C1+TST000:160:SLY'
NAD+C2+TST:160:SLY'
ERC+100::SLY'
RFF+Z07:FI_TST000_JVH0101'
RFF+AIV:Z03_1_TST_TST000_3645282041'
ERC+100::SLY'
RFF+Z07:FI_TST000_JVH0301'
RFF+AIV:Z03_1_TST_TST000_2825971886'
UNT+16+1'
UNZ+1+4444'

27: Rejected

UNA:+.? '
UNB+UNOC:3+TST:SLY+TST000:SLY+090908:1511+5555'
UNH+1+PRODAT:D:97A:UN:E2FI01'
BGM+Z03+0000000000117+9+AB'

UNA:+.? '
UNB+UNOB:2+TST000:SLY+TST:SLY+090908:1515+6666'
UNH+1+APERAK:D:96A:UN:E2FI01'
BGM+++27'

DTM+137:200909081211:203'
DTM+ZZ:0:805'
NAD+FR+TST:160:SLY'
NAD+DO+TST000:160:SLY'
NAD+C1+TST:160:SLY'
NAD+C2+TST000:160:SLY'
LIN+1+1+FI_TST000_JVH0101:::SLY'
DTM+92:200909092100:203'
CCI++ZZ1'
CAV+ZIV:::1'
RFF+AIV:Z03_1_TST_TST000_3997802499'
RFF+VC:Contract1'
NAD+IT++++Haukitie 2 B 4+ESPOO++02150+FI'
LIN+2+1+FI_TST000_JVH0301:::SLY'
DTM+92:200909092100:203'
CCI++ZZ1'
CAV+ZIV:::1'
RFF+AIV:Z03_1_TST_TST000_5449852983'
RFF+VC:Contract2'
NAD+IT++++Vanhamäentie 420+MIKKELI++50600+FI'
UNT+23+1'
UNZ+1+5555'

DTM+137:200909080915:203'
DTM+178:200909081211:203'
RFF+ACW:0000000000117'
NAD+FR+TST000:160:SLY'
NAD+DO+TST:160:SLY'
NAD+C1+TST000:160:SLY'
NAD+C2+TST:160:SLY'
ERC+50::SLY'
FTX+AAO+++Contract start time too near'
RFF+Z07:FI_TST000_JVH0101'
RFF+AIV:Z03_1_TST_TST000_3997802499'
ERC+50::SLY'
FTX+AAO+++Contract start time too near'
RFF+Z07:FI_TST000_JVH0301'
RFF+AIV:Z03_1_TST_TST000_5449852983'
UNT+18+1'
UNZ+1+6666'